



Solutions for
sustainable
**animal feed
production.**

Animal Feed Processing.

Table of contents.

One step ahead	3
Solutions to feed your product	4
Efficient raw material intake.	6
Storage solutions.	7
Gentle and efficient conveying systems.	8
Sieving systems for all needs.	11
Dosing & weighing systems	12
Grinding	14
Mixing solutions	16
Multi-NIR Inline System.	18
Online particle size measurement solution	19
Pellet Mills	20
Conditioning & Hygienization	22
Intelligent process optimization with our pellet mill companion	23
Cooling.	24
Coating & post pelleting applications.	25
Bagging your finished products	26
Ship loading & unloading.	27
Industrial dust aspiration solutions.	28
Automation.	30
Feed safety.	32
Extensive range of services.	34
Top quality dies and rollers	35

One step ahead. **Your ideal partner.**

As a technology leader and solution provider with long lasting experience in the industry, we support you in every aspect of the production of reliable animal feed. We work closely with you to keep you one step ahead.

Benefits at a glance:

- Superior quality through state-of-the-art, tailored solutions
- Feed safety concepts for safe feed
- Professional project management and project execution
- Full automation solutions with intelligent process optimization and industry 4.0 ready
- We work closely with you and share our technology know-how in trainings, support and advisory services
- One stop shop – full solution provider
- Your reliable partner for the lifetime of your plant



From idea to realization. **Total solution provider.**

We offer process solutions and consulting to transform a wide range of feed ingredients to safe, healthy and nutritious animal feeds. Be it in the form of pellets or mash we aim at highest animal welfare and feed conversion rate. The technology underlying our animal feed processing installations and the sound process expertise of our engineers will help you to produce animal feeds to the most rigorous hygiene requirements, while mitigating cross-contamination.

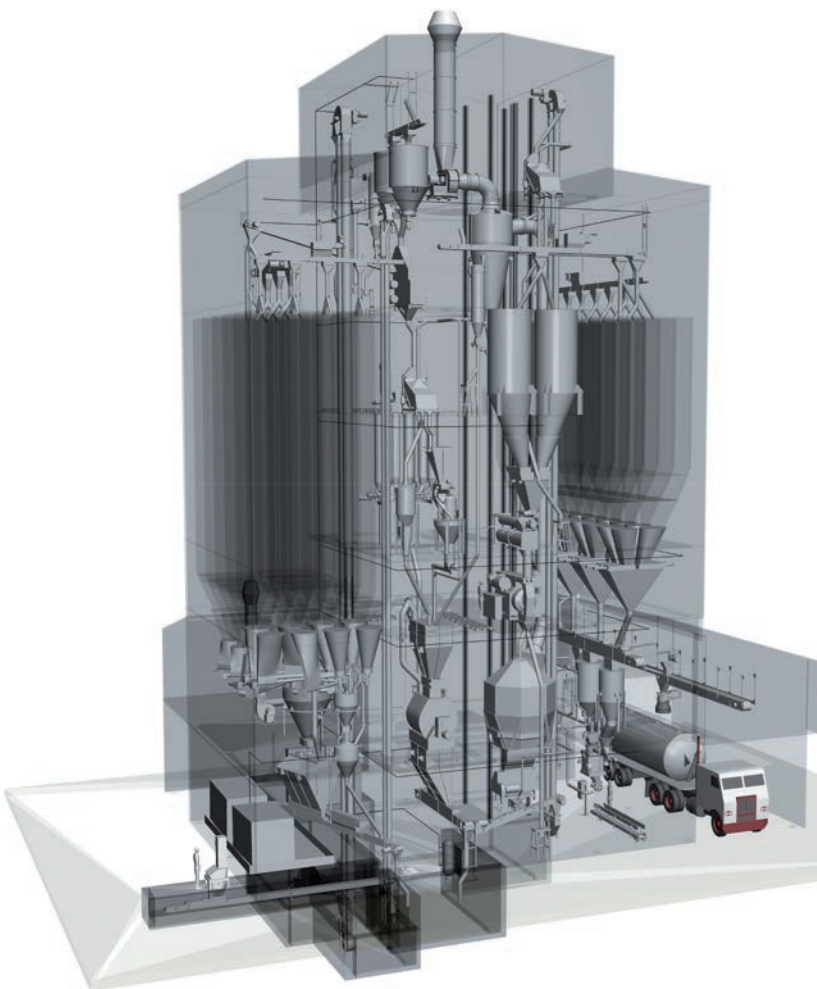

1. Raw material intake
2. Storage
3. Conveying & dedusting systems
4. Cleaning
5. Dosing & weighing
6. Grinding
7. Mixing
8. Conditioning & hygienization
9. Pelleting
10. Cooling
11. Coating
12. Bagging & bulk loadout



The perfect starting concept. **Efficient raw material intake.**

Each process starts with the reception of raw materials. Whether it is poured by hand or unloaded by tractor, truck or train – we will design a complete intake system for any bulk material that you need to create your feed.

Thanks to many years of experience in the planning and implementation of the intake process, we know how to bring you highest possible efficiency in material reception by taking various safety concepts into consideration. We customize the intake or you can choose from a selection of standardized dimensions, offering a quick and easy order processing. This also includes a harmonized aspiration system.

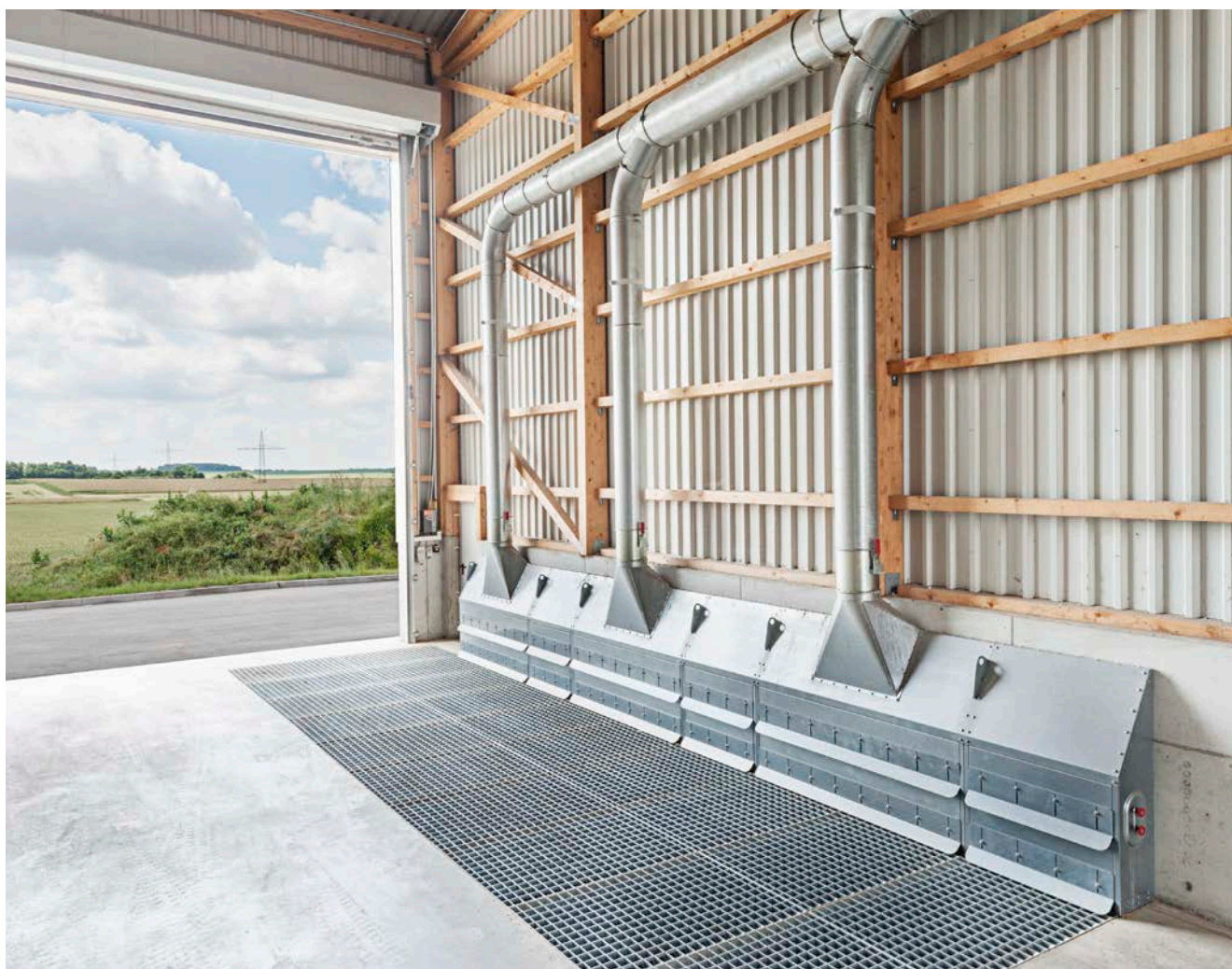

Optimizing storage conditions and process flow. **Storage solutions.**

After a thorough analysis, we use our wide range of storage options to create a solution for your mixed feed process – all from a single source. This can include not only raw material storage prior to processing but also storing and buffering of ingredients and bulk materials within the process. Various solutions are available:

- Macro, minor, micro ingredient bins
- Various hoppers and buffer bins
- Steel silo
- Concrete silo
- Flat silo & flat storage



From intake to loadout. **Gentle and efficient conveying systems.**

Our conveyor lines cover all applications throughout your feed value-added chain, from raw material intake to conveying finished pellets. We will customize a system to meet your space and process needs, using any combination of elevators, trough chain, belt and screw conveyors as well as pneumatic conveying systems.



Chain conveyor.

For conveying mealy, fine and coarse grained materials.

- Applicable as unidirectional or bidirectional conveyor
- High operating reliability and smooth running
- Optimal sanitation and easy maintenance
- Manages horizontal and slightly inclined conveying



Belt and bucket elevator.

For bulk materials with particle sizes up to 50 mm.

- State-of-the-art sanitation technology
- High throughput capacity with low energy requirement
- Available with rectangular as well as circular casing



Belt conveyor.

For gentle and economic conveying over long distances.

- For sensitive as well as aggressive products
- Conveyor lengths of up to 500m are possible

Tubular screw conveyor.

For conveying very specific material.

- All mealy plus fine and medium grained materials that are not friable, only slightly abrasive, and non-sticky
- Applicable as horizontal, vertical and inclined conveyor
- Distribution, collection, proportioning, or discharge of material
- Available in various diameters and lengths



Trough screw conveyor.

For horizontal or upward use.

- Conveying, distribution, collection or discharge
- Mealy plus fine and coarse grained materials
- Easy and convenient maintenance
- Optimal sanitation and hygiene standards available
- Low power consumption



Pneumatic conveying.

For feeding abrasive bulk materials through airlocks into a pneumatic conveying system.

- Provided with the appropriate fittings
- Very good residual discharge





We can offer a wide range of solutions ranging from coarse, pre and main cleaning to primary sieving ahead of hammer mills for different fractions as well as to separate fines before bagging.

Separation and cleaning you can rely on. **Sieving systems for all needs.**



Drum sieve.

Coarse cleaning of grain and other bulk materials reduces wear to the downstream equipment in the production process. Our drum sieve reliably eliminates coarse particles.



Throw sieve.

The throw sieve is applied for the primary sieving ahead of hammer mills as well as in multi-stage grinding to obtain different fractions without changing screens in the hammer mill. But also to separate pellets and crumbles for final sifting.



Screening machine.

Our compact screening machines are the ideal choice for the small capacity range up to 50 t/h (for wheat).



Magnetic separator.

The magnetic separator reliably removes ferrous items from granular or mealy products out of a continuous product stream.



Universal cleaning machine.

To be able to process different types of grain into high-quality products, high-end cleaning machines are required which also meet the growing requirements for hygiene, throughput, efficiency and economical operating costs. Our universal cleaning machine is synonymous with this.

Precise – like a Swiss watch. Dosing & weighing systems.

The quality of your mixed feed essentially depends on the accuracy of the dosing and weighing of the ingredients in your recipe. Our solutions are designed to feed and proportion each ingredient with the high precision you need.



Batch scale.

Matched with the batch size, our scales come in various capacities and designs like circular, square or rectangular. The electronic load cells ensure an exact weighing result.



Silo scale.

Our silo scale is an automatic, discontinuous, totalizing hopper scale without any jacketing. It can be used as an intake, transfer or loading scale for various products. It meets the international OIML R107 guidelines regarding accuracy, resolution and explosion protection.



Micro-dosing system.

Our micro-dosing system is designed to proportion and feed essential ingredients such as vitamins, additives and trace elements into your animal feed with high precision, achieving a dosing and weighing accuracy of 0.1% of scale capacity.

Rotary bin discharger.

The rotary bin discharger is designed to discharge mealy or granular bulk materials from storage bins and hoppers to downstream processing machinery and scales.



Double vane flap.

The double vane flaps discharge free-flowing bulk materials from storage bins, scales, and hoppers and feed materials to mixers. Their optimized design ensures low material residues, which effectively prevents cross-contamination.



Slide plate discharger.

This slide plate discharger, operated by pneumatic cylinder, has been especially developed for large capacity bins and elevators. Its smart design allows it to be used also for products which are non-free-flowing.

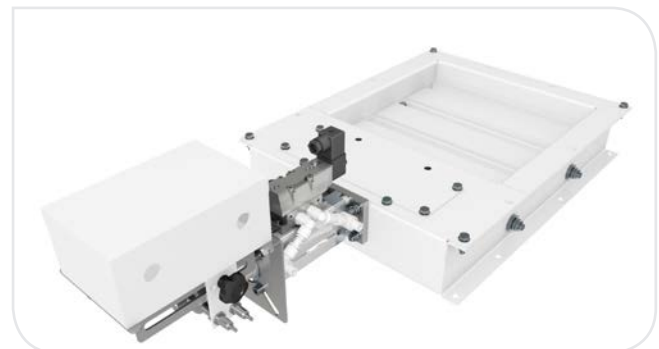

Screw feeder.

The screw feeder can be used for high-precision volumetric proportioning or for feeding material at a controlled rate to a gravimetric system.



Powerful size reduction. **Grinding.**

With our versatile grinding portfolio, consisting of horizontal and vertical hammer mills as well as roller mills, we can cover all of your size reduction needs. We can bring you solutions for pre- and post-grinding, coarse and fine grinding, as well as for creating crumbles of various sizes.



Vertical hammer mill.

With its vertical grinding shaft, our Vertica™ grinding and pre-grinding hammer mill can deliver up to 25% energy savings. A smaller footprint, change-over and sanitation benefits make it ideal for animal feed, grain/oil milling and biomass industries.



Horizontal hammer mill.

Our horizontal hammer mill is a high efficiency grinder for size reduction in various feed & food processing industries. Generally applied for dry materials with a bulk density of 0.2-0.8kg/dm³, it convinces through high production flexibility and minimal downtime.



MultimpactMax™.

This hammer mill provides industry leading throughput capacities on a wide range of friable and fibrous products with exceptionally uniform particle size distribution from coarse to fine applications. It is available for the North American and South American markets only.

Cracking mill.

The high performance cracking mill is for optimal processing of oilseeds and various applications in the feed milling industry, providing an unrivaled ease of maintenance, full automation control as well as highest throughput rates. It is available in a modular design with up to 3 roll pairs, 2 different roll lengths and diameters.



Pellet crumbler.

This grinder is applied for crumbling feed pellets and for size reduction applications in multistage grinding systems in various industries. The modular concept allows a combination of up to 3 crushing stages in one crumbler with optional automatic roll gap adjustment system.



Different feeder to hammer mills.

For our grinding portfolio we offer matching feeder which achieve continuous feeding into the respective hammer mill and remove heavy particles as well as ferrous items. The feeding rate is automatically adjusted to the load of the mill.



Quick mixing results. **Mixing solutions.**

Mixing plays a key role in the processing of your feed. Our batch mixers with different holding capacities and smart paddle design offer you a quick and precise mixing cycle. Optional liquid addition equipment can deliver the right liquidity too.



Batch mixer.

The Speedmix batch mixer is capable of processing free-flowing dry solid substances at a dry mixing time of 90s. Hygienic design and easy maintenance make it the productive choice for animal feed and many other material processing industries.



Batch mixer with chopper.

The single shaft batch mixer in stainless steel with optional choppers is specially designed for the flour milling and bakery industry. It shortens your mixing time to just 90 seconds, with excellent mix quality.



Twin-shaft batch mixer.

The twin-shaft paddle mixer is applied within various industries. It processes free-flowing dry solid substances in short mixing time, featuring easy maintenance and high capacity on a small construction height.



Benefits:

- Short mixing time of 90 s
- Consistent mixing quality CV 2 – 5 %
- Short discharge time \leq 10 s
- Low cross-contamination \leq 0.05 %
- Low maintenance requirement
- Liquids addition of \leq 5 %

Intelligent optimization of moisture, fat and protein. **Multi-NIR Inline System.**

The Multi-NIR Inline System is a complete system for measuring and automatically optimizing the moisture, fat and protein content in animal feeds. The measurement can take place along various points in the feed production process, e.g. at raw material intake, at the mixer, at the feed hopper and at the cooler. Moisture and fat content can be optimized at the mixer.

Up to 6 measurement points can be connected to one spectrometer. Each measurement takes only 3 seconds and is extremely precise with a standard error of prediction of 0.3% for water and fat, and 0.5%/0.8% for protein*. This makes it possible to significantly reduce the recipe-specific safety buffers and thus decrease production costs.

** 0.5% for raw materials, 0.8% for mixed feed*

Compact and Robust Design.

Developed for industrial use, the Multi-NIR Inline System offers the highest degree of durability against interfering factors such as vibrations and temperature fluctuations. The system is distinguished by high precision and durability because the measuring head and spectrometer are spatially separated.



Benefits:

- Constant feed quality
- Increased production output
- Increased profitability due to optimized water, protein and fat content
- Energy savings during pelleting
- Traceability and feed safety

Optimal particle size for your livestock. **Online particle size measurement solution.**

The Bühler online particle size measurement solution automatically takes a sample from each batch at the mixer. The sample is then analyzed by an optical sensor and a granulation curve is created. Hence, it replaces the time consuming manual sieve analysis.

Improved digestibility for maximum animal performance.

Our online particle size measurement solution delivers a constant overview of the particle size distribution in your process. This enables you to better use your raw material, create optimal particle sizes for different livestock and increase the stability of your pellets. All this can result in a higher Feed Conversion Rate and finally increased animal performance.

Traceability.

Having the historical data at hand you will not only have a solid base for process analysis and optimization but also a reliable track record in case of product back tracing.



Benefits:

- Higher profit
- Constant animal performance
- Increased process transparency
- Projectable maintenance
- Reduced production cost

Striving for the perfect pellets – your partner for compacting your creation.

Pellet Mills.

As a global technology leader, we fully understand how to pellet a wide range of materials. Our expertise focuses not only on creating pellets per se, in partnership with you we strive for a process that improves the feed conversion rates, nutrition and safety of your pellets.

Our extensive pellet mill portfolio covers a wide range of applications.

Die diameters: from 420mm - 1200mm

Capacities: ranging from 5 up to 80 t/h (depending on product)

Options like central lubrication system, heating mats, slippage detector, execution in ATEX 22, and many more are available depending on the machine type.



Pellet mill with direct drive.

Developed in close cooperation with leading feed millers, the Kubex T pellet mill is different from anything else in the industry. A specially designed direct drive system powers the production of feed pellets with an unprecedented level of efficiency. The result is an output of up to 80 metric tons per hour. Due to its compact design it is also easier to use and maintain than anything comparable in the market.



Pellet mill with 1 V-belt motor.

Our pellet presses from the Kubex series have been used successfully for generations. Characterized by low maintenance requirements and a durable design they deliver high pellet quality and enable a flexible operation when product recipes change frequently in your process.



Pellet mill with 2 V-belt motors shouldered.

This design version covers another state-of-the-art compacting technology. Thanks to the power transmission via shouldered motors those pellet mills require less footprint and run with reduced circumferential die speed.



Benefits:

- Sturdy construction
- Easy to maintain
- Stable, reliable production
- Reduced footprint

Pre-treatment for top pellets. **Conditioning & Hygienization.**

This modular system combines modern conditioning and hygienization technology, which can be adapted to your pelleting process. High feed hygiene, reduction of start-up time and productivity increase are just some of the many advantages.

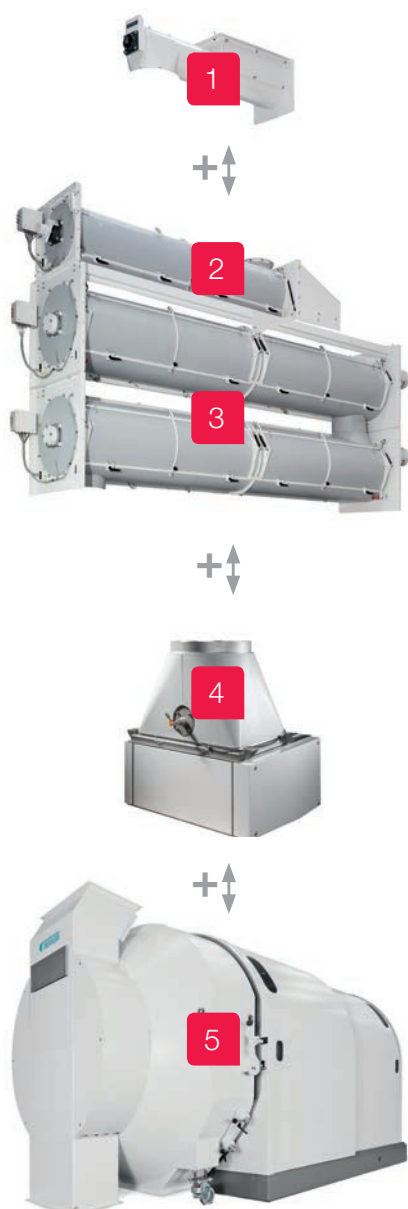

1. Feeder.

The feeder ensures optimal product dispensing from the pellet mill surge hopper to the conditioner.

2. HYMIX conditioner & HYMIX Plus.

The conditioner enables the heating of compound feed particles to temperatures of up to 95 °C. In addition to steam, up to two additional liquids can be added. Thanks to the optimised design of the mixing tools, residue quantities are considerably reduced.

Compared to the conventional conditioner the HYMIX Plus conditioner comes in a more sophisticated design with additional temperature sensor and intelligent control unit to achieve a reduction of start-up time.

3. HYTHERM retentioner.

The system can be supplemented with retentioners for increased hygiene requirements. This allows retention times of 30 up to 360 seconds. It has best machinery hygiene properties thanks to the optimised design of the screw segments and the large service door.

4. Optiflow.

The Optiflow system ensures continuous product input and protects the pellet mill from current peaks and fluctuations. This reduces the risk of roller slippage, increases pelleting performance and extends the service life of the entire pellet mill.

5. Pellet mill and line control.

Combine thermal pre-treatment with a Bühler pellet mill to create a high performance complete system. In order to utilize the complete performance capability of the pellet line, we recommend to connect it to a Bühler control system.

#Record #Analyze #Optimize #Excel.

Intelligent process optimization with our pellet mill companion.

With our pellet mill companion we provide you with IoT and cloud service for maximum competitiveness through continuous improvement with the help of algorithms. Our monitoring and reporting, adapted to your individual feed mill design, convinces with excellent production parameters.

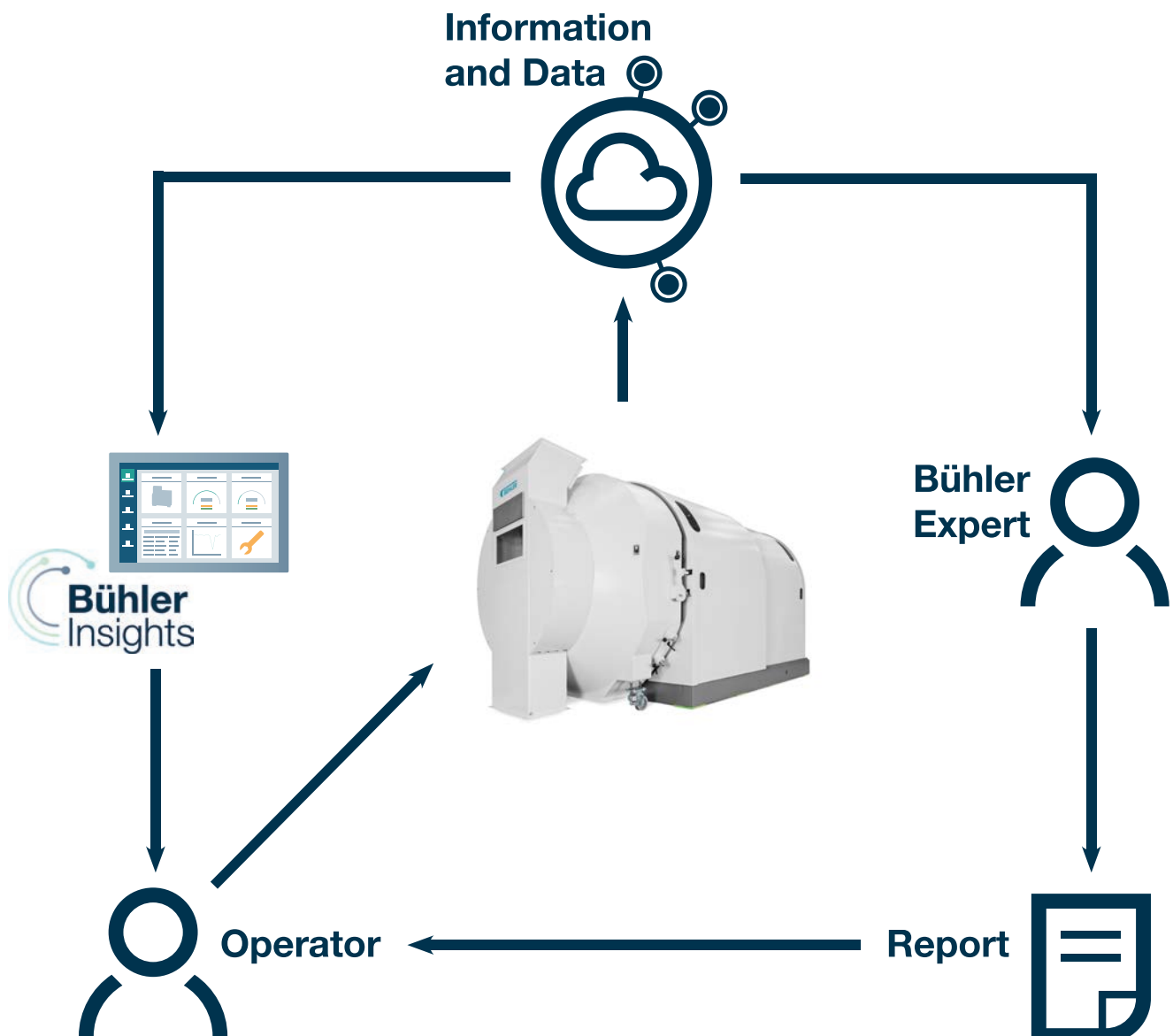

Ready for handling and storage. **Cooling.**

The cooling of your hot pellets is essential for further handling and proper storage. Our extensive portfolio of countercurrent coolers offers you an efficient, hygienic and homogeneous cooling process. Different discharge systems ensure gentle handling with minimal fines tailored to your product.



Conical discharge.

The conical screen bottom creates a uniform product layer and therefore an even air distribution across the cooler which results in a very homogeneous cooling. Due to the angle of the cone the pellets move gently to the outlet leaving almost no product residues behind.



Flatbed discharge.

Compared to the conical discharge, the flatbed coolers take up less space in terms of construction height. The rotating rack distributes the product layer evenly and the discharge systems are designed the way that the pellets stay intact with minimal pellet breakage or fines.

Our portfolio of coolers contains various types and sizes and covers capacities ranging from 7 – 60 t/h.

Upgrading your feed pellets. **Coating & post pelleting applications.**

Coating your feed pellets with fats and oils, colorants and flavorings, vitamins or enzymes enables you to offer your products in a higher quality grade at higher values. Our coating and post pelleting application solutions can add this capability to your line.



Uniform coating through high-precision control.

The coating drum enables you to simultaneously coat and thus upgrade your products with up to three different liquids – with a liquids addition rate of max. 8 percent of the product throughput. Design versions of mild steel or high-grade stainless steel for throughputs up to 30 t/h offer you a wide range of choices.

Pack your bags. Bagging your finished products.

As a total solution provider, we can offer you a range of customized concepts for bagging your finished mixed feed, ready for dispatch. Our automatic systems handle your bags very gently and achieve optimal stacking quality.



Single-spout bagging station.

The MWPF single-spout bagging machine, designed for bagging capacities of 7 to 20 bags/minute, is suitable both for freeflowing and for non-freeflowing as well as for friable materials. A dust-tight bag spout and an optional aspiration system ensure a clean machine environment.

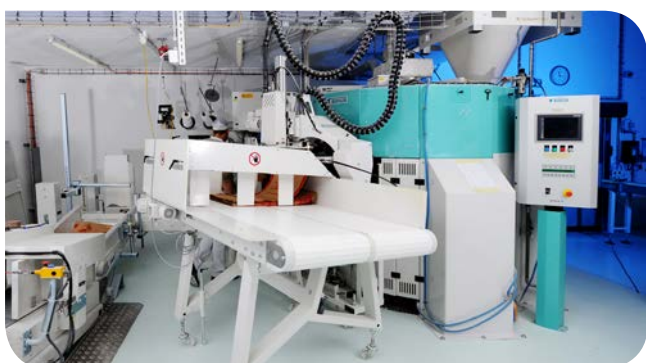

Bagging carousel.

Characterized by its high performance, accuracy and sanitation standard, it is suitable for the following applications:

- Packing of cereal grain flour, feed meals, and premixes (up to 18 bags per minute).
- Possible containers: open-mouth bags of paper, plastic, jute, or cotton (weight: 10 kg to 50 kg).



Palletizer.

For automatic palletizing of various bag types and optimal warehouse space utilization, our palletizer solution offers:

- Modular design for a wide variety of installation types
- Suitable for bag weights ranging from 10 to 50 kg
- Adaptable to bags of paper, plastic or jute
- Capacity up to 20 bags per minute with 5 bags per layer

Bon voyage! Ship loading & unloading.

An astonishing 1.5 million tons of grains and meals are shipped over the seas worldwide everyday. This required highly efficient grain terminals that can handle high capacity and volumes in a cost-effective manner.



Portalink mechanical unloader.

The Portalink, Bühler's continuous mechanical unloader, has been designed to achieve the key customer requirements for importing grains and meals:

- Maximum unloading efficiency
- Unrivalled reliability, ensuring continuous operation
- Low operating costs
- Low wear and tear with known technology



Portacombi.

Portacombi, a Portalink and loader in one combined ship unloading and loading system are often used at facilities with import and export activities that handle cereal grains, oilseeds and derivatives. The Portacombi can also be used to unload product from a sea-going ship on one side of the pier and load it directly onto a barge on the other side, saving time and money for complex product transfer routes.



Portaload.

Grain and derivative transshipment is a business in which a 1 cent difference per ton can create a competitive advantage. Keeping ship loading costs low and efficiency high is therefore vital. Portaload ship loaders are sturdy, hard-wearing, and equipped with advanced instruments, enabling them to load quickly, safely and efficiently at low operating costs.

For optimal protection of your plant and environment.

Industrial dust aspiration solutions.

Our dust aspiration systems can be used along your entire feed value-added chain to meet all relevant market requirements. We can help you to avoid explosive atmospheres and protect your employees, environment and plant. Valuable fine product can be led back into the process stream, reducing waste.



Round filters and total separators.

- High and low pressure filters available
- Minimum consumption of compressed air with the same efficiency and reduced operating costs
- Certified and designed according to the currently relevant standards and guidelines for explosion protection



Spot filters.

- For conveying equipment
- No loss of product because dust is recycled back into product stream
- Dust-free working areas thanks to air being drawn off from the places of origin



Dust aspiration for reception hopper.

- Flexible and individual design along with easy installation thanks to sustainable modular construction
- Top suction capacity via below floor and above floor aspiration through adjustable suction slits



Cyclone.

- Optimal degree of separation for high volumes with moderate requirements for residual dust content
- Compact, maintenance-free design at low cost

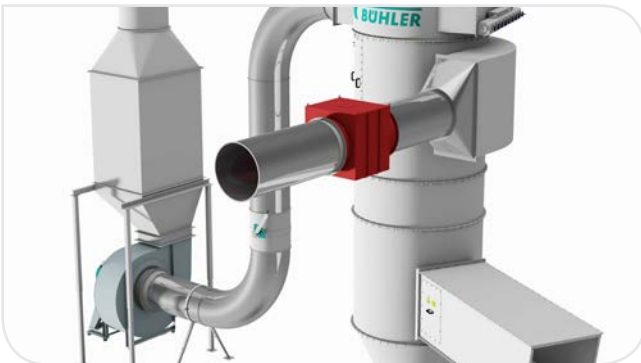

Components for a complete system.

- Aspiration: Fan, silencer, deflector hood, air pipe system
- Explosion protection: Rotary valve, check valve, bursting disk, flameless pressure relief

Your complete one-stop shop. **Automation.**

Drawing on global experience from over 5'000 installed plants, we know how to bring all of your process automation needs together in one place. Together with you, we define the right state-of-the-art Automation concept for a sustainable plant control. With the following services we make sure, that your plant control will not only meet the current requirements but also persists in the long-run.

What we offer:

Consulting

- Control concepts for process and solution
- Safety, security and energy management
- Tailored solutions, designed specifically for your plant
- Energy consulting

Engineering

- Automation project management
- Working with leading automation and equipment partners
- Hardware engineering, from sensors and cabinets to operator stations
- Software engineering, covering PLCs, process visualization, SCADA, MES and IoT

Manufacturing

- Control panels, motor control panels and local boxes
- Mid-/low-voltage distribution
- Power compensation

Electrical cable planning and installation

- Electrical engineering
- Electrical installation and supervision
- Energy monitoring

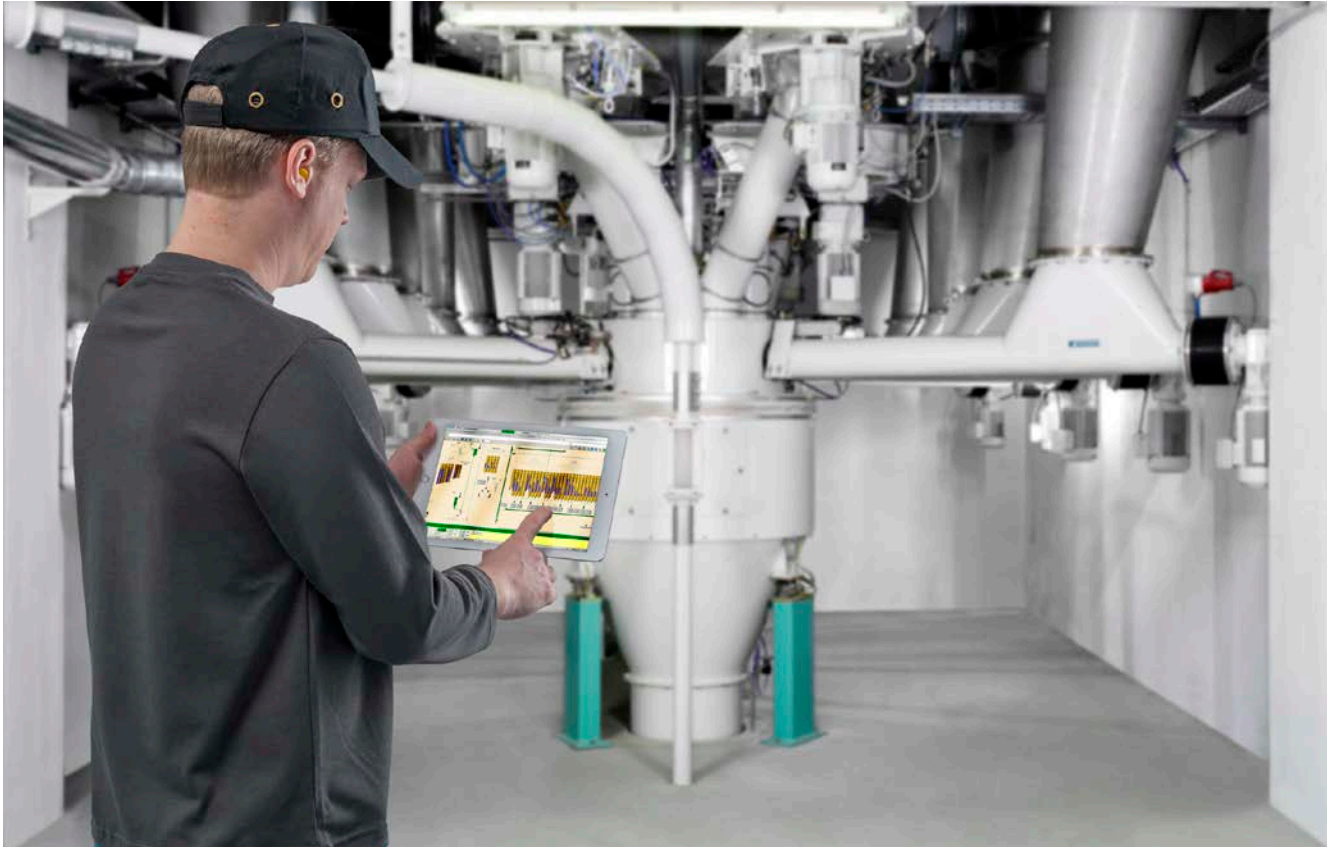

Commissioning

- I/O testing and device calibration
- Dry-run tests and plant control system commissioning
- Process start-up
- On-site production support

Training

- Tailored training or standardized modules
- Plant operation, troubleshooting, maintenance or application-specific topics
- At your plant, at the Bühler Academy or online

IoT and digital services

- Connectivity to Cloud
- Predictive maintenance and augmented automation
- Information security, intelligent sensors, Big Data and IoT applications

Customer Service

- Remote support, 24/7, anywhere around the globe
- Ongoing local preventative maintenance and emergency callout
- Industry and process specialists at your service

Improved animal health and performance. **Feed Safety.**

Safe and nutritious feeds are crucial for optimal animal growth, strong immune responses and high fertility as well as low feed conversion rates and mortality. Not only economically but also legislatively meeting higher feed safety standards is a common challenge all animal feed producers across the world are facing today.

We are your ideal partner in producing safe and healthy feeds thanks to our broad technological knowledge, process know-how, global experience of building feed plants and state-of-art automation solutions as well as equipment supply along the entire feed production value chain.

Our solutions:

- Mycotoxin control
- Validation and process monitoring
- Training and consulting
- Salmonella inactivation via heat treatment
- Hygienic design of equipment and facilities
- Prevention of cross contamination
- Early warning systems

Benefits:

- Increase competitiveness due to higher quality
- Ensure compliance with legal requirements and industrial standards
- Enhance brand image and reputation
- Provide clean feeds with significant mycotoxin reduction



From engineering to training. Extensive range of services.

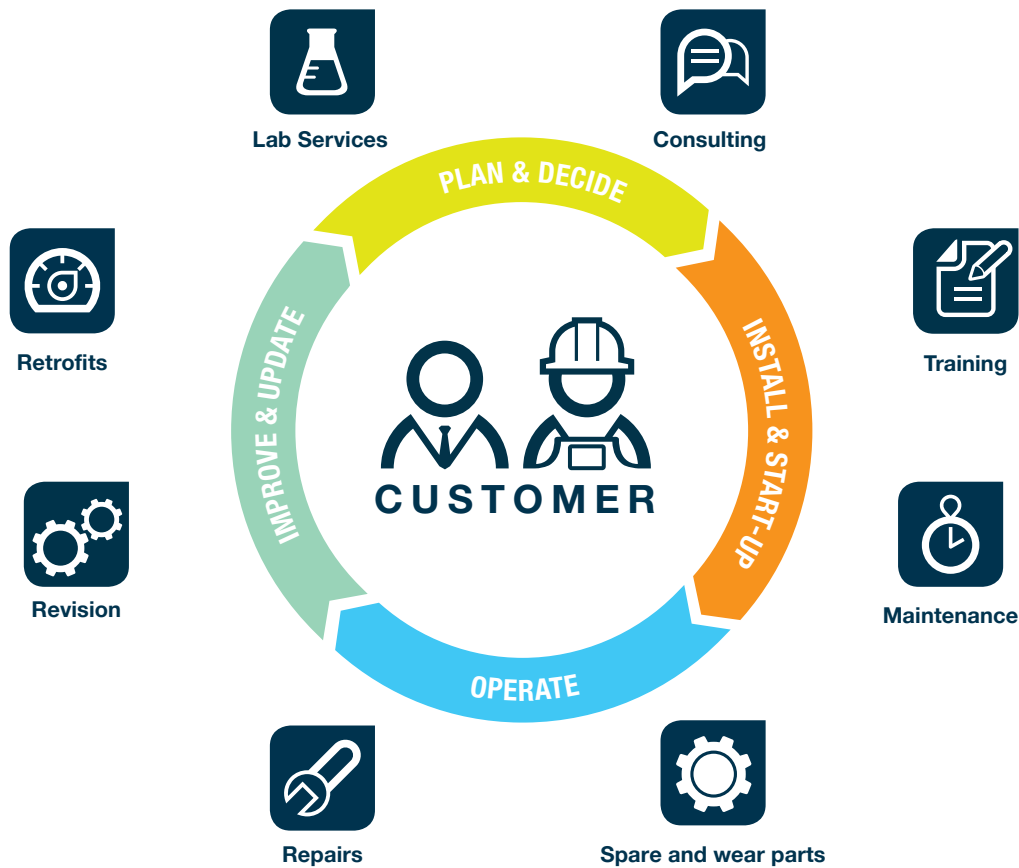

Lab Services

The laboratories offer a broad range of analyses and testing of food and technical materials in order to innovate processes and improve equipment for our customers.

Spare and wear parts

Highest standards of reliability apply to original Bühler spare and wear parts. They are perfectly adjusted and ensure performance and production safety.

Training

At Bühler training centers – or at any site worldwide – specially trained experts pass on their hands-on expertise and knowledge to customers' employees.

Revision

Bühler evaluates, over-hauls, adjusts or renews customer installations, including Bühler and non-Bühler machines.

Consulting

Strategic, plant performance, or energy consulting are just some of the consulting services to improve product quality, production processes and energy efficiency.

Repairs

Dedicated to minimizing downtime in the event of an incident: Fast and reliable technical repair service via the Bühler eTicket or the Bühler Helpline – worldwide, 24/7.

Maintenance

Packages are adjusted to fit production cycles to prevent downtime, loss in production efficiency or product quality, ranging from individual services to complete outsourcing of maintenance.

Retrofits

With individual upgrades and conversion kits time-worn Bühler machines will perform to current standards of technology and efficiency.

For longer service lives and more profit. **Top quality dies and rollers for all brands.**

Bühler is a proven specialist in the manufacture of high-precision and durable dies and rollers. Our wide range includes not only products for our own pellet mills, but also for the pellet mill models of other manufacturers. Customers worldwide rely on our longstanding experience in the design and manufacture of dies and rollers in outstanding quality.

Fast commissioning and short delivery times.

Bühler's dies and rollers are characterised by easy installation and commissioning. Thus, our customers benefit in the shortest time possible from the product advantages. Thanks to flexible production and a comprehensive inventory of high-quality forged blanks, our dies and rollers are available worldwide as quickest possible.

Higher throughput rates and longer service lives.

Thanks to their outstanding quality, Bühler's dies and rollers enable higher throughput rates and ensure a longer service life than comparable products. Maximum cost efficiency means that investments are paid off in no time.

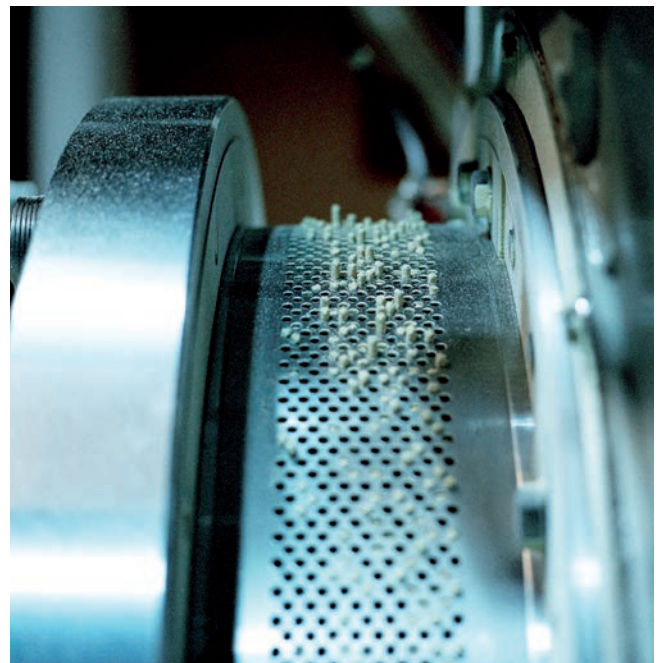

Bühler example calculation:

Electric energy savings per year*:

3'750 \$

or 37'500 kWh

or 19.8 t CO² less emissions

Start-up benefit during commissioning**:

200\$ additional profit

**Example calculation based on pellet mill throughput of 15t/h; 150kW el. power consumption; 5'000 running hours a year; 0.10 \$ per kWh costs for electricity; 5% el. savings.*

*** Start-up time to full capacity (15t/h): 0.5 hours*

Benefits

- Up to 5% energy reduction due to Bühler specific parallel hole pattern
- Fast commissioning up to 10 times faster due to running in of dies
- Up to 60t feed production advantage during start-up of a new die
- Short delivery times thanks to stock capacities worldwide
- Dies and roller shells for all brands

Bühler AG

CH-9240 Uzwil
Switzerland

T +41 71 955 11 11
F +41 71 955 66 11

www.buhlergroup.com/feed
feed@buhlergroup.com