



Oilseeds Preparation.

Products ahead of their time. **Processes a step ahead of your needs.**

When it comes to the preparation of oilseeds like soybeans, rapeseed, sunflower seeds or corn, you need reliable processes and machines that turn raw materials into profitability. With Bühler at your side, you have a partner that can offer you both: sophisticated process know-how and modern technologies – all from a single source and customized to meet your individual business needs.



Bühler's product portfolio and services cover the entire oilseed preparation value chain, from ship unloading and loading to grain storage and handling, weighing, cleaning, drying, aspiration systems, conditioning, cracking, dehulling and flaking as well as grinding and pelleting of hulls and extraction meal. In addition, our engineers and project managers deliver optimal plant design that meets

your requirements – ensuring a plant that is well equipped to provide top productivity, high availability and optimal final products. Guaranteed and proven daily for the past 80 years in oil mills worldwide with capacities of up to 20,000 tons or more every 24 hours. What's more we offer product training and follow-up assistance.



When everything runs according to plan from seed to flake, it can only be Bühler.

Every step matters in the process of turning a raw material into the final product, and every raw material should have its own process chain. With its reliable processing technologies, Bühler makes sure all these forms of production harmonize with one another during the oilseed preparation process so that you can get the most out of your seeds.





● intake, cleaning, weighing



● conditioning



● cracking, dehulling



● flaking

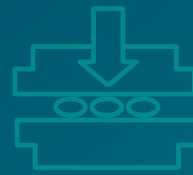

● pressing



● hull aspiration



● extraction



● hull & meal treatment

● crude oil



● bagging



Preparation of soybeans.

Dehulling efficiency meets low operation costs.

When it comes to the preparation of soybeans prior to direct extraction, Bühler offers its competence in the designing and implementing of front-end, warm and hot dehulling processes or processes without dehulling. The hot dehulling process sets itself apart through lower energy costs and is suitable for beans containing up to

14 percent of moisture. In all mentioned processes, the beans will be optimally conditioned, cracked, dehulled and flaked so that you can get the maximum oil out of them during extraction. The overall fiber content is also reduced, delivering high protein content in the extraction meal.

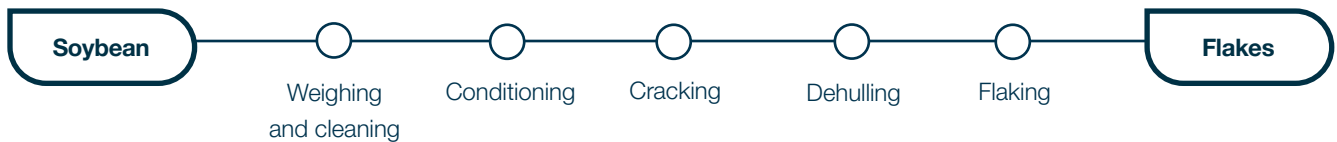

Related Bühler machines:

- Scale
- Cleaning Machines
- Magnet
- Destoner
- Conditioner
- Fluid Bed
- Cracking Mill
- Cylindrical Cascade Aspirator
- Hull Separator
- Flaking Mill

Preparation of soft seeds.

Consistently thin flakes for efficient extraction.

Soft seeds, such as sunflower, cotton, copra, palm and rapeseeds, have higher oil content than soy and cannot undergo direct extraction. Instead, the oil content is reduced to below 20 percent by screw presses and then extracted from the expelled cake in a solvent extraction system. For the processing of rapeseed, Bühler offers its expertise in designing and implementing warm and cold

preparation processes. Copra and palm kernels must further undergo a prereduction by a hammer mill before being processed by a cracking and a flaking mill. The flaking mill and its ability to produce consistently thin flakes are key to the efficient extraction of all oilseeds. A promise guaranteed by Bühler.

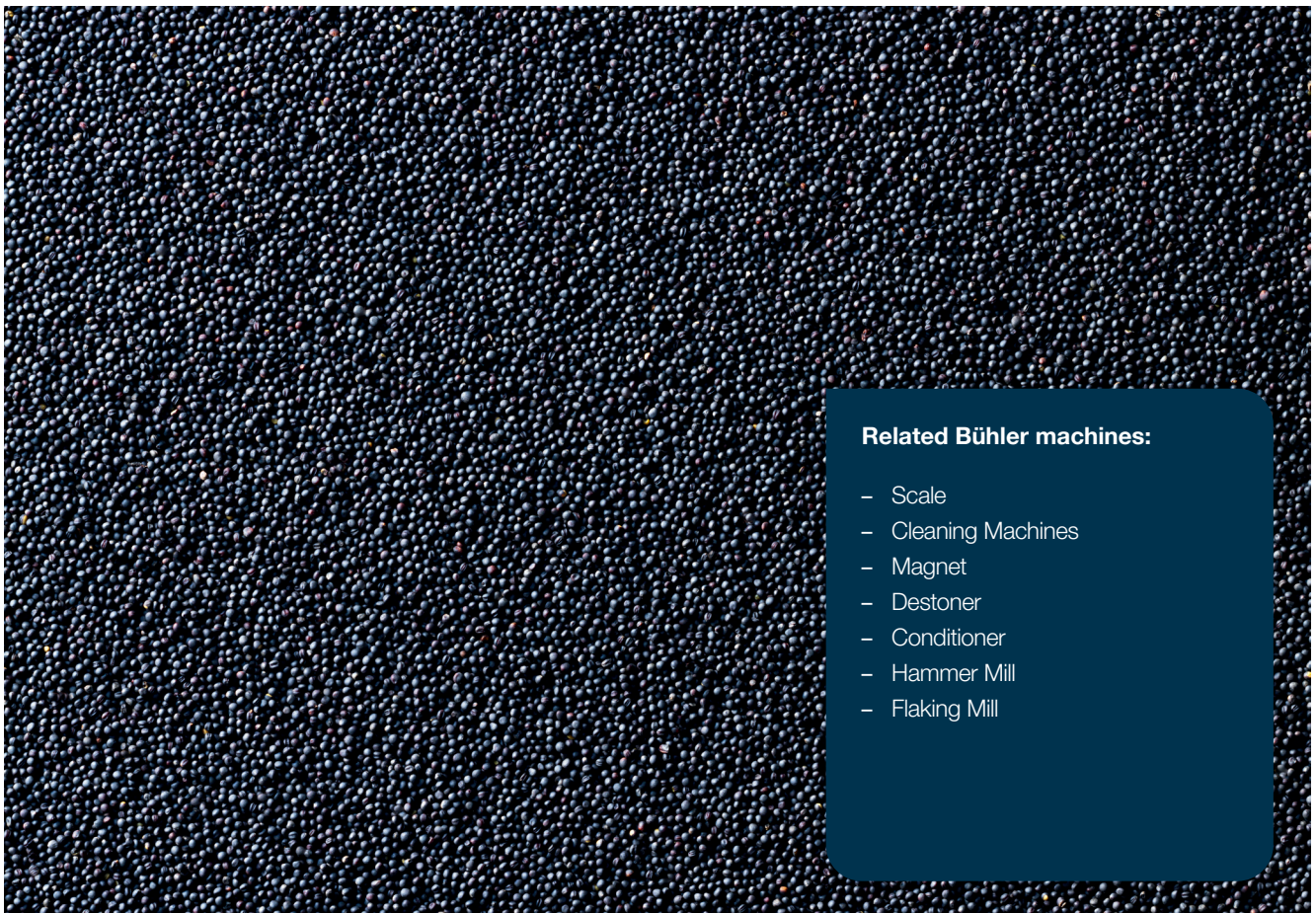

Related Bühler machines:

- Scale
- Cleaning Machines
- Magnet
- Destoner
- Conditioner
- Hammer Mill
- Flaking Mill

Preparation of sunflower seeds. **High-capacity dehulling processes.**

Bühler's sunflower preparation solution delivers top dehulling results leading to a higher protein content in the extraction meal. You have the choice between one- or two-stage sunflower dehulling. After the first dehulling stage, the dehulled product contains less than 16 percent

residual hulling fragments. With a second round, you can further reduce this amount to less than 12 percent to obtain an even higher protein content in the extraction meal. After the second stage, a sifter ensures that oil loss during hull separation is as low as possible.

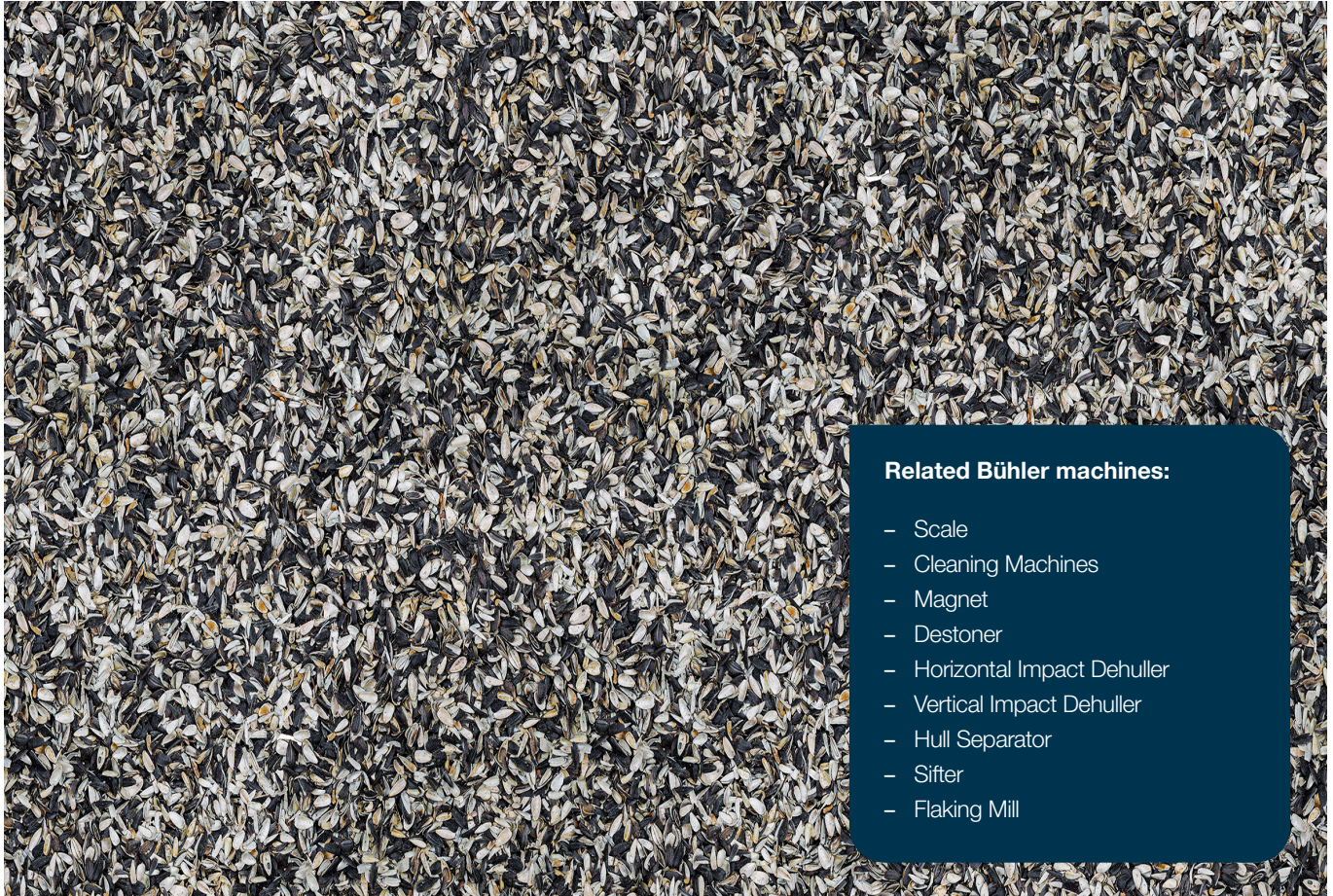
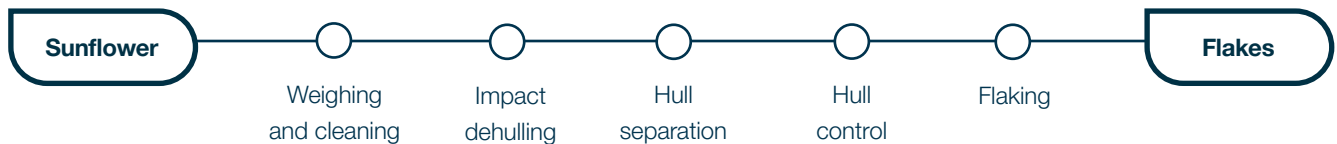

Processing of extraction meal and hulls.

Adding value to your by-products.

In the production of feed, extraction meals are used as an important protein carrier when combined with other feed ingredients. Separated sunflower and soybean hulls have half the thermal value of heating oil and can be used as an alternative energy source instead of gas, electricity or

heating oil, e.g. as fuel for steam generation in boiler rooms. Bühler offers processes and technologies for the grinding and pelleting of hulls and extraction meal – so that you can get more out of your by-products.



Related Bühler machines:

- Sieve
- Horizontal Hammer Mill
- Vertical Hammer Mill
- Pellet Mill
- Cooler
- Oscillating Screen

Preparation of soybeans for direct extraction. **Equipment for cleaning, cracking and flaking.**

Soybeans are not only processed to obtain oils and extraction meals, but also for manufacturing high-grade products such as white flakes, protein concentrates and isolates. The food processing industry is transforming these semi-finished products into an ever-expanding range of foodstuffs. Bühler has developed preparation processes in this field that fully satisfy the extracting requirements placed on the end products.

Oilseed weighing and cleaning.

Bühler offers an extensive line of equipment covering all oilseed weighing and cleaning needs such as scales, cleaning machines, magnets and destoners. In this area, customers benefit from the synergies generated by Bühler's activities as a supplier to a large number of food processing industries.

Size reduction and flaking.

Roller mills for cracking and flaking have always been a Bühler specialty. With their broad technological basis, Bühler systems are equipped to withstand the harsh operating conditions they are exposed to. As a result, the entire operation benefits from low maintenance requirements.

In Bühler's front-end dehulling system cold and dry soybeans are processed and can be flaked down to a flake thickness of 0.3 mm or less.

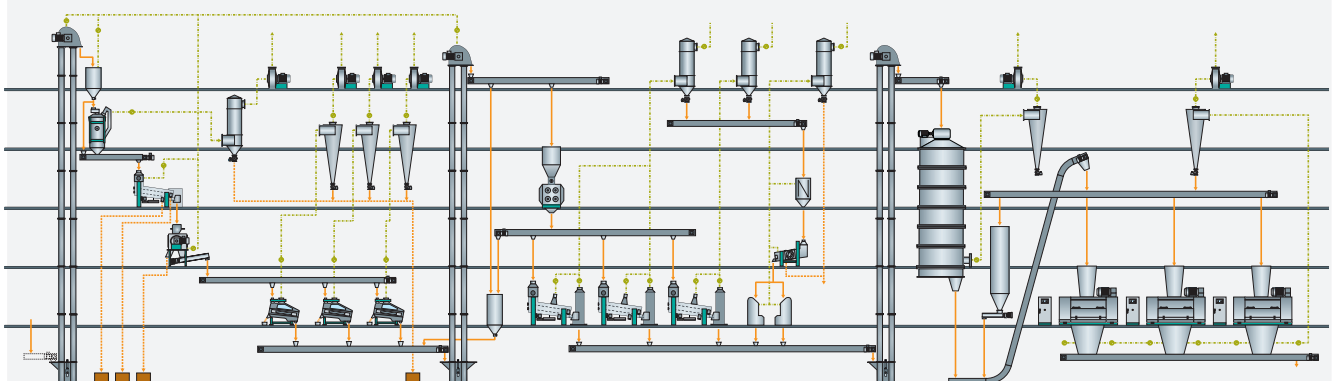

Cleaning Machine SMA 203-3 and SMA 206-6

- Efficient cleaning, grading and sorting of oilseeds
- Suitable for pre-cleaning and main cleaning
- Compact design and high operating reliability
- Easy and quick screen exchange



Flaking Mill OLFB

- High-throughput flaking mill with 500 t/24h or more capacity
- Flake thickness adjustment during operation
- Low energy consumption
- Easy maintenance, safe operation, compact design



Destoner MTSC

- Excellent degree of separation
- High specific capacity
- Various applications
- Easy operation and maintenance



Cracking Mill OLCB

- Throughput of up to 1,500 t/24h for soybeans
- Consistent cracking quality
- Roll gap adjustment during operation
- Roll package for easy roll exchange



Soybean popping system for efficient dehulling. Equipment for hot dehulling.

A reduction of your energy costs can be achieved with the hot dehulling process. Here, soybeans with a moisture content of up to 14 percent only need to be heated once instead of twice as in the traditional front-end dehulling process.

Soybean conditioning and dehulling.

Bühler's "popping" system is characterized by its low steam consumption and its ability to perform without dryers and tempering bins. With this system, the cleaned beans are heated in a conditioner to the point of perspiration and are then treated with hot air in a fluid bed. This results in flash evaporation of the perspiration water present between the hulls and the kernels, causing the hulls to be detached from the kernels and some to "pop off". If required, this equipment can also be used for drying.

Air-recycling principle.

In the roller mill, the hot beans are cracked, resulting in the splitting of the soft kernels and the breaking off of the brittle hulls. The subsequent air-recycling separator removes the hulls from the kernels. Thanks to the air-recycling principle applied during this process, no cooling takes place. Instead, the kernels, still hot, are fed to the flaking mills before their oil is extracted in the extraction system.

Bühler's soybean hot dehulling process delivers lower thermal energy costs than the conventional dehulling process.

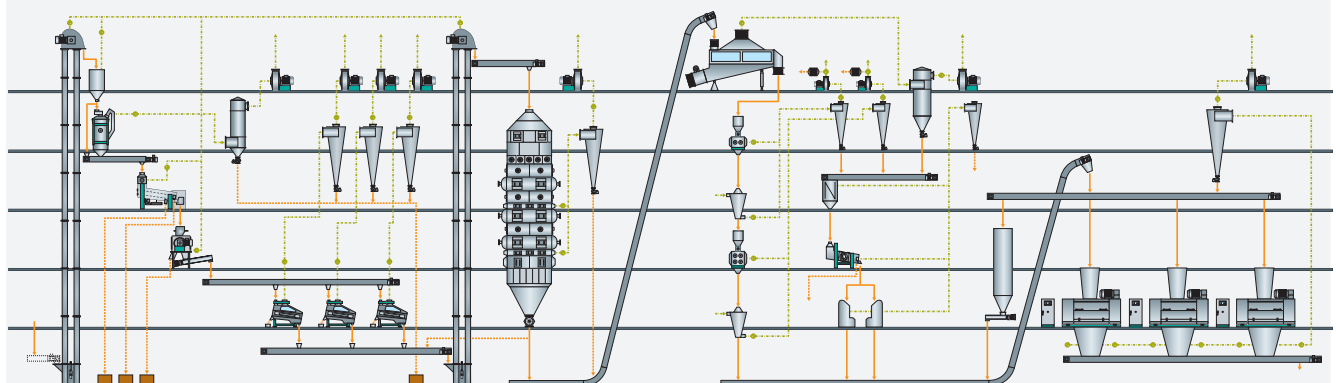

Conditioner OLKA

- Excellent heat transfer: efficient and uniform oilseed conditioning
- Low steam consumption
- Drying option
- High durability steam tubes

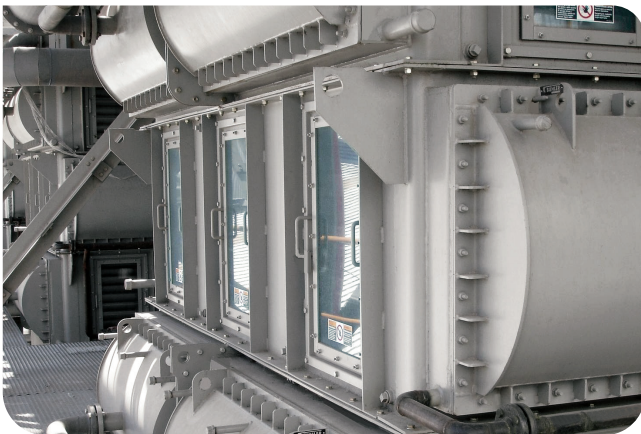

Centrifugal Screen DMHX

- For separating fine husks from kernels in combination with a screening machine.
- Rotor equipped with nylon brushes and beater bars for high separating efficiency
- Available in four different sizes

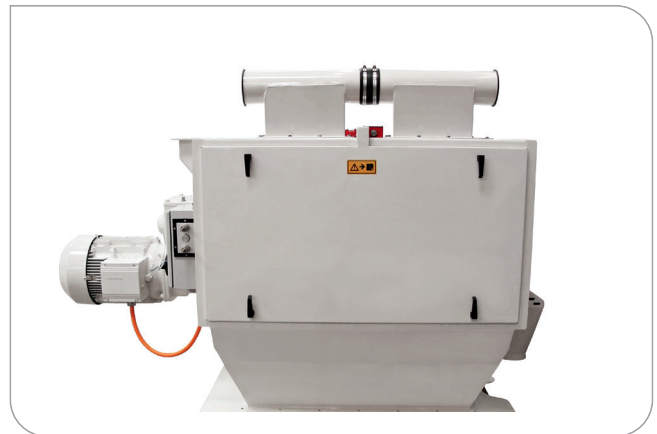

Cylindrical Cascade Aspirator OLSA

- High-throughput aspirator
- Multiple separation zones for high-efficiency hull separation
- Robust, durable design



Fluid Bed OLHA

- Cost- and energy-reducing design
- Controlled soybean exposure for best dehulling results
- Low heat loss and reduced operating costs
- Easy to operate and to maintain



Dehulling of soft seeds - efficient hull separation. **Equipment for sunflower dehulling.**

Sunflower hulls contain very little protein and hardly any oil, and they have a high crude fiber content. In addition, the hulls are rough and low in density. Dehulling reduces the volumetric throughput into the system and keeps the abrasive hulls away from the processing equipment. Bühler has developed a special line of equipment for the dehulling of sunflower seeds.

Sunflower impact dehulling and hull separation. Hull control.

After cleaning, the sunflower seeds are separated from the hulls by Bühler's horizontal or vertical impact dehullers. The seeds are impacted by centrifugal force against the wearresistant jacket. Upon impact, the hulls rupture and are separated from the seeds without significant damage to the valuable kernel. This results in a mixture of kernels and broken hulls.

The hulls and kernels within that mixture are very similar in actual weight. For this reason, the hulls are separated by the hull separator in an aspiration process.

During the second hull separation stage, some fine kernel particles are removed with the hulls. These fine kernel particles are aspirated together with the hulls from the second hull separation stage. For this reason, these hulls are passed through a sifter for hull control in order to recover the fine kernel particles, reducing the oil loss among the hulls.

Bühler's 2-stage sunflower dehulling process reduces rest hull content to less than 12 percent and minimizes oil loss with hulls.

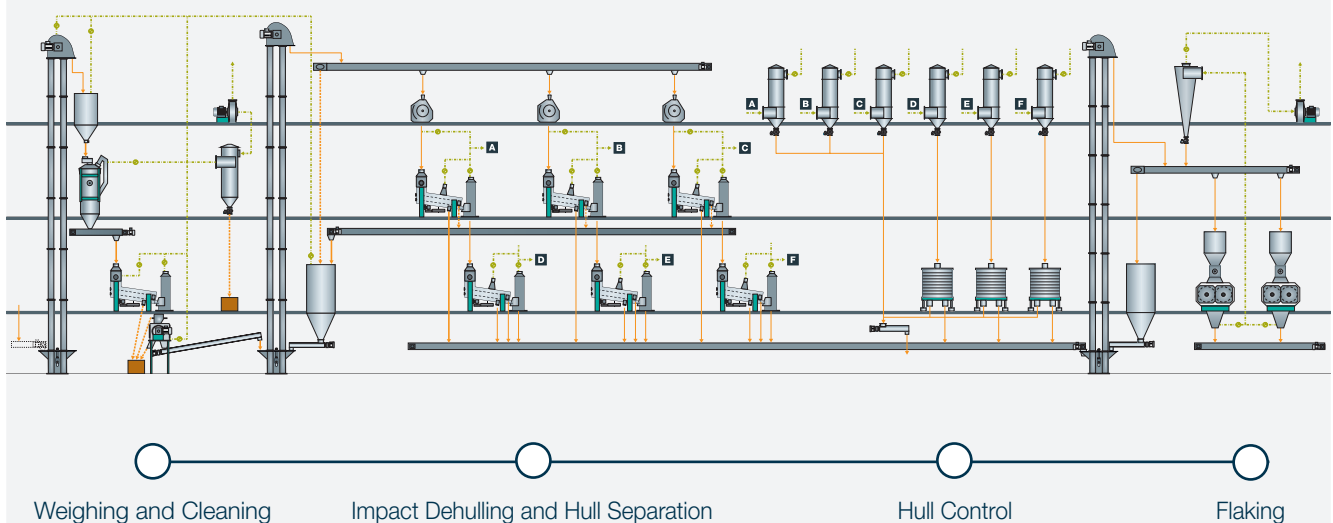

Horizontal Impact Dehuller DGBB

- Smooth sunflower dehulling with low fines
- Consistently high product quality
- Simple adjustment of impact chest
- Easy exchange of rotor blades
- Integrated magnet



Hull Separator SMA 203-3 OL

- Excellent separation of sunflower and soybean hulls from kernels
- High-capacity hull separation
- Easily adjustable aspiration devices
- Quick access to screens

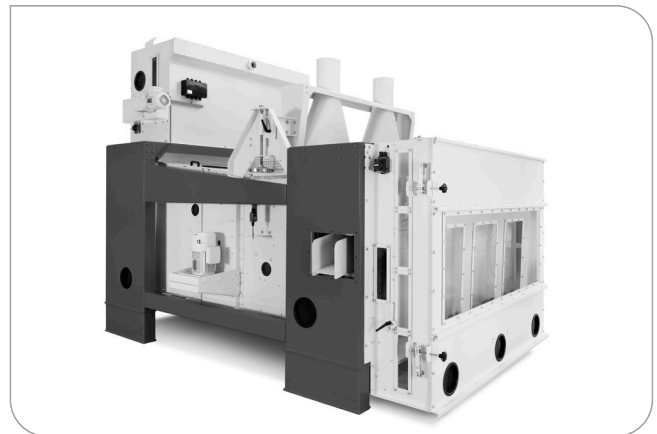

Vertical Impact Dehuller DOSB

- Suitable for multi-seed dehulling
- Perfectly controlled feeding process with magnet
- Top dehulling results and low fines production



Plansifter MPAQ/MPAR

- High throughput capacity with small footprint
- High flexibility thanks to various sieve frames
- Minimized maintenance and cleaning times



Reliable technology for processing of by-products. **Equipment for grinding and pelleting of ex-meal.**

To make more of the by-products obtained during the preparation and extraction process, Bühler offers a variety of processes and technologies for the grinding and pelleting of extraction meal and hulls.

Grinding of extraction meal and hulls.

Extraction meals are used in the production of feed, so very specific particle size distribution is required for this process. To achieve this, the fines are first screened with only the overs being sent to the hammer mill for grinding. The oscillating sieve eliminates fines before processing, minimizing the electric power needed. Hulls are directly transported to either a horizontal or vertical hammer mill.

Pelleting systems for extraction meal and hulls.

Following the grinding process, extraction meals and hulls are pelleted, improving their flow characteristics and facilitating handling, storage and transportation. After the pellet mill, the granulates pass through a cooler and an oscillating sieve.

Bühler's horizontal or vertical hammer mills are installed in numerous oil mills worldwide for the grinding and pelleting of extraction meal and hulls.

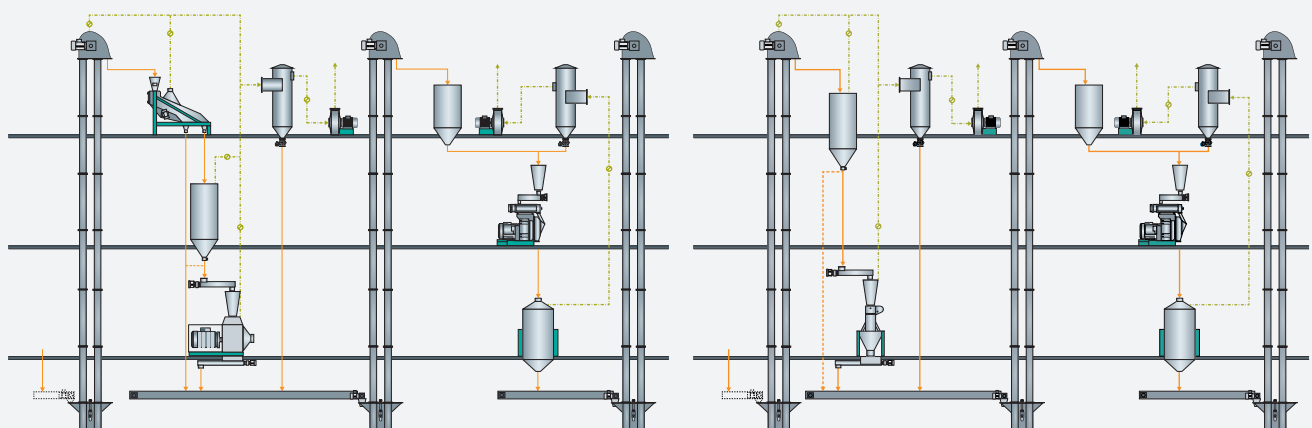

Extraction meal: Sieving and grinding Pelleting and cooling Hull grinding Pelleting and cooling

Vertical Hammer Mill DFZK

- Up to 25% less energy consumption compared to horizontal hammer mill
- Considerably less aspiration air needed for the grinding process
- High operating reliability
- Easy exchange of hammers and screens



Pellet Mill Kubex™ T DPEE/DPEF

- Outstanding energy efficiency thanks to direct drive
- High pelleting capacities for oilseed extraction meal
- Variable die speed for optimal pellet quality and die lifetime



Horizontal Hammer Mill DFZP

- Powerful grinding with up to 400 kW motor power
- Hammer tip speed of up to 118 m/s
- Designed for minimized downtimes



Oscillating Sieve DFTA

- High efficiency
- Low power requirement
- Compact and efficient



Storage and handling of oilseeds. **Sustainable solutions.**

Extensive logistics planning is required in today's modern plants in order to facilitate a smooth flow of materials from seed receiving, production and storage to the shipment of final products. Bühler's wide range of materials handling and storage installations has proven to be a dependable solution to this challenge.



Solutions from a single source.

Bühler works closely with customers to develop, engineer and build customized solutions from standardized, proven components. Bühler's choice of products for oilseed handling and processing includes:

- A complete line of mechanical and pneumatic conveying systems
- Loaders and unloaders for rail, truck and ship transport
- Vertical drying and cooling systems
- Dedusting systems like cyclones, round filters, spot filters and dedusting walls for intake hoppers
- Plant control systems/automation

Global expertise. Local presence. A lifetime of customer service.

Bühler customer service provides assistance not only to keep your machines, plants and facilities running at a high operational level, but also to prolong lifetime, thus maximizing return on investment.



Bühler's service includes:

- Roll refluting and grinding from local service stations
- Fast access to help in your language and time zone
- Competent service specialists throughout the entire product service life – from installation to commissioning and maintenance
- Genuine Bühler spare parts
- Innovative retrofit packages
- Preventive maintenance concepts
- Analysis and consulting
- Standardized and customized training and continuing education courses



Bühler AG

CH-9240 Uzwil
Switzerland

T +41 71 955 11 11
F +41 71 955 31 49

oilseeds@buhlergroup.com
www.buhlergroup.com/oilseeds