



Bühler  
Aqua Feed  
**Solutions.**

Innovations for a **better world.**

**BUHLER**

# Proven extrusion processes

## Integral element of the production process

In the production of Aqua Feed, it is important to ensure the ideal formulation for a complete diet for food fish or ornamental fish. More importantly, gentle processing into a product that can be preserved is crucial. The focus is on the extrusion process. As a cooking and shaping process, this has a lasting impact on the end product characteristics. The pre-treatment and post treatment processing steps also contribute to overall performance.



### Optimal quality with optimized costs

The single most important goal during production of fish feed is the creation of a complete diet that enables optimal ingestion. At the same time, feed should maintain the animal's health. This will maximize the conversion rate and the meat quality while minimizing the costs.



### Blending, Mixing and Grinding

Raw materials account for over 80% of total production cost, formulated and continuously optimized on the basis of commercial and nutritional criteria. A fine-grinding system can reduce the raw component blend to an average particle size of about 100 to 250 microns. The blend is then conveyed pneumatically to the control sifter.



### Control sifting

A sifter, especially suitable for processing finely ground for fatty fish feed formulations is required to eliminate insoluble substances like bones, scales, sand, and fibers, which can clog die holes smaller than 1.5 mm. For this reason, Bühler recommends a mesh aperture smaller than 70% of the die hole diameter.



### Extrusion process

The extrusion process is essentially a cooking process during which starch-containing components are decomposed and proteins are denatured. Combined with other ingredients, a hydrophilic yet water-stable matrix is created. The required heat is added mainly in the form of direct steam in the pre-conditioner. In the extruder, the mass, preheated to about 95 °C, is further heated by mechanical processing so that temperatures ranging from 120 °C to 140 °C are achieved. The patented "Density Control System" allows the steam pressure of the hot dough mass to be controlled while the mass is still inside the extruder. This enables the sinking or floating characteristics to be controlled across a wide range of bulk densities without compromising the cooking degree. The energy released from the extruder can be recovered almost without any emissions to the conditioning stage.



### Shaping and Cutting

Die hole geometry is crucial in the process, as the hot product melt has to be depressurized, shaped, and cut, especially small die holes up to 0.8 mm require an optimized number of holes and a wear-resistant die plate. A movable cutting device enables precise control with even knife exchange during the process. Since a considerable volume of moisture is evaporated at this point, the addition of hot air and a good aspiration is recommended in order to prevent condensation and agglomeration of the products.



## Drying

The hot and steaming product very rapidly releases the free surface moisture to the hot air stream. Once the surface has been dried, the drying action is limited by the diffusion rate inside the product, and the air stream can be reduced. Due to this physical conditions, the drying process is diverted into different segments with different temperature profiles. This optimized process allows very fast, gentle, and non-deforming drying to the necessary final moisture content of 8% to 10% even of soft and sticky products.



## Coating and Cooling

After drying, the dried extrudates are coated while warm. During this stage, it is possible to add fats, flavorings, attractants, colors, and even powdered ingredients. Depending on the temperature and the specific surface area of the extrudates, up to 10% liquids can be absorbed in the coating drum and the subsequent cooler. For higher oil quantities up to 40%, it is common practice to apply vacuum coaters.



# Optimized process chains for Diverse fish feed solutions



## Salmon

For feeding salmonids, sturgeons and sea water-fish such as yellow tail, sea bream and sea bass, you need pellets with high levels of protein and fat content that sink slowly in saline water. Our solutions produce high-quality pellets with a good water absorption rate and the high water stability you need.

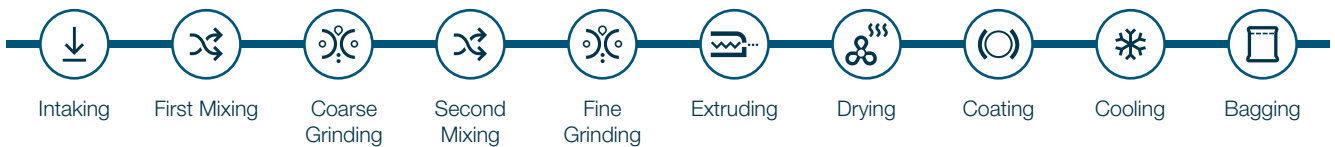

## Tilapia

We create complete solutions for producing floating pellets with moderate protein and fat content for feeding warm-water species such as tilapia, eels and catfish. We can help you choose between a single screw and twin-screw extruding process to meet your demands and optimize production costs.

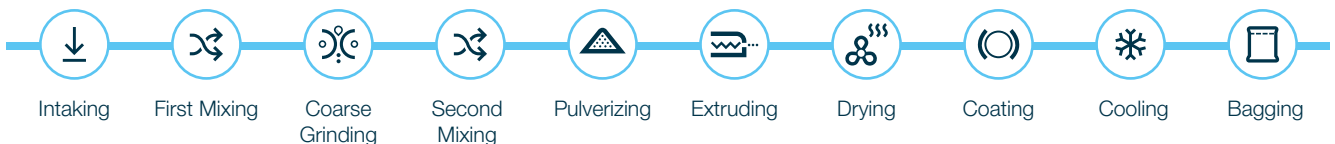

## Shrimp

For shrimp feed, you need to be able to formulate fast-sinking pellets, which retain their elastic structure even after hours in the water. Our technology gives you the precise control of the cooking and shaping you need to create a quality product with minimal waste.

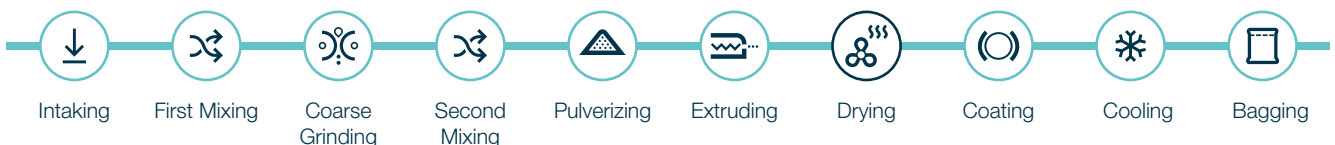



## Focus on final product characteristics **A variety of shapes, color, and density**

In Aqua Feed production, it is important to ensure the formulation of a complete diet for aquaculture or ornamental fish. At the same time, gentle product process that preserves the formula is crucial.

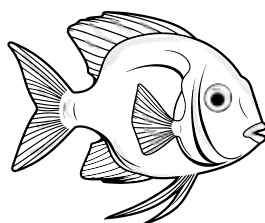
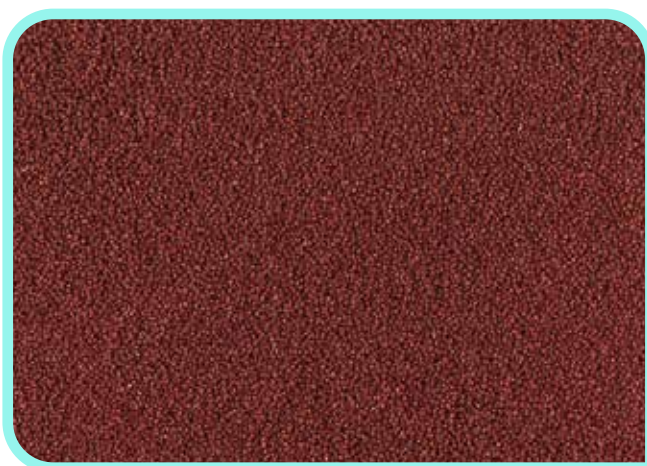

### **Micropellets**

Very small, accurately cut, floating or sinking pellets starting at 0.3 mm, for feeding ornamental fishes and larvae.

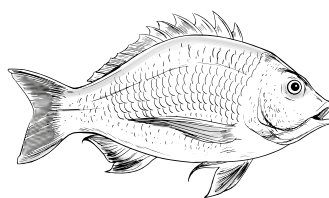

### **Floating feeds**

Pellets with moderate protein and fat contents for feeding warm-water species such as tilapia, catfish, eels, etc.





#### **Sinking feeds**

Pellets with high protein and fat contents, with high water absorption rate and high water stability, sink slowly in saline water. These pellets are appropriate for feeding salmonides, sturgeons, and sea water fish such as yellow tail, sea bream, sea bass, etc.

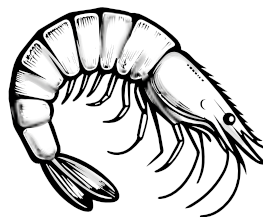

#### **Shrimp pellets**

Fast-sinking pellets retain their elastic structure even after hours in the water.



# Core elements in Aqua Feed production

## The crucial processes for highest quality

### Grinding



#### Hammer mill Granulex® 3 Series

The Granulex 3 Series hammer mill is a cost-efficient solution for size reduction in feed processing industries. It delivers excellent grinding quality, high production flexibility and minimal downtime.

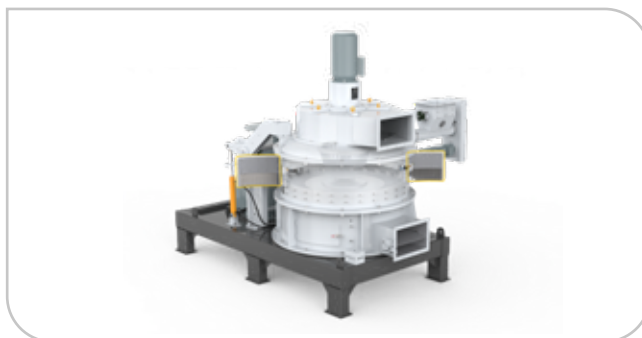

#### Pulverizer Pulverex™ 3 Series

The Pulverex 3 Series is high-efficiency pulverizer which breaks down raw material and is generally used in ultra-fine applications. It utilizes the latest technology to achieve the highest throughputs with consistent quality.

### Extruding



#### Twin-screw extruder

High torques and pressures, varied screw speeds and precise control are essential in any state-of-the-art twin-screw extruder. Easy cleaning and accessibility of all critical zones ensure excellent sanitation, an important aspect in marking high-quality products.

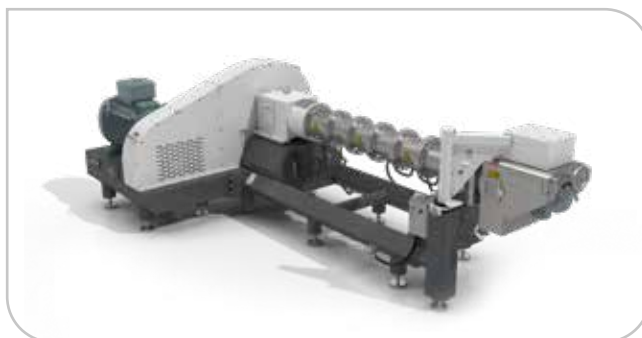

#### Single-screw extruder

The single-screw extruder is a cost-effective tool for cooking and shaping products, and the standard solution for floating Aqua Feed. The machine is characterized by its adjustable process section, various drive options, accessories such as water-cooled or electrically heatable barrels, and its ease of operation and automated control system.

## Drying



### Two-pass conveyor dryer SmartFeed II

SmartFeed II is designed to improve customer revision, maintenance, fines management, and collection, resulting in safer operation, easier cleaning, and increased uptime. With a capacity up to 12 t/h, it ensures superior airflow for uniform moisture content and increased saleable yield. The engineered airflow control maintains consistent temperature and velocity distribution across the entire product bed, delivering exceptional product quality.



### Three-pass conveyor dryer SmartFeed III

With a capacity up to 18 t/h, SmartFeed III ensures superior airflow for uniform moisture content and greater saleable yield. The engineered airflow control guarantees consistent temperature and velocity distribution across the entire product bed, delivering exceptional product quality. Additionally, its design enhances customer revision, maintenance, fines management, and collection, leading to safer operation, easier cleaning, and increased uptime.

## Coating



### Batch spray coater

The batch spray coater is applied for Aqua Feed production with high liquid adding accuracy. The machine has a quick-detachable nozzle device and big inspection doors on both sides, easy clean and maintenance.



### Newbex 3

The Newbex 3 is a highly efficient and reliable coater designed for a wide range of applications in the post-spraying process of extruded pellets for Aqua Feed. The machine ensures optimal coating performance, enhancing the nutritional value and palatability Aqua Feed. Additionally, its nozzles are evenly distributed in a ring of 8 positions to maximize spraying uniformity, guaranteeing consistent coverage of the pellets.

# Extensive range of services From engineering to training

You know your business better than anyone. Combining our engineering expertise, industry know-how and practical skills with your knowledge, we can give you the best tailormade support for your business.

In the event of a breakdown, you need the necessary spare parts as fast as possible. That is why we run stock centers worldwide, so you can get quick access to high-quality spare and wear parts.

We provide complete machine installation for your equipment. Call us 24/7 to get your job done. We train our 750 service engineers worldwide to handle your equipment and processes. We are committed to delivering the highest quality of service as fast as possible.

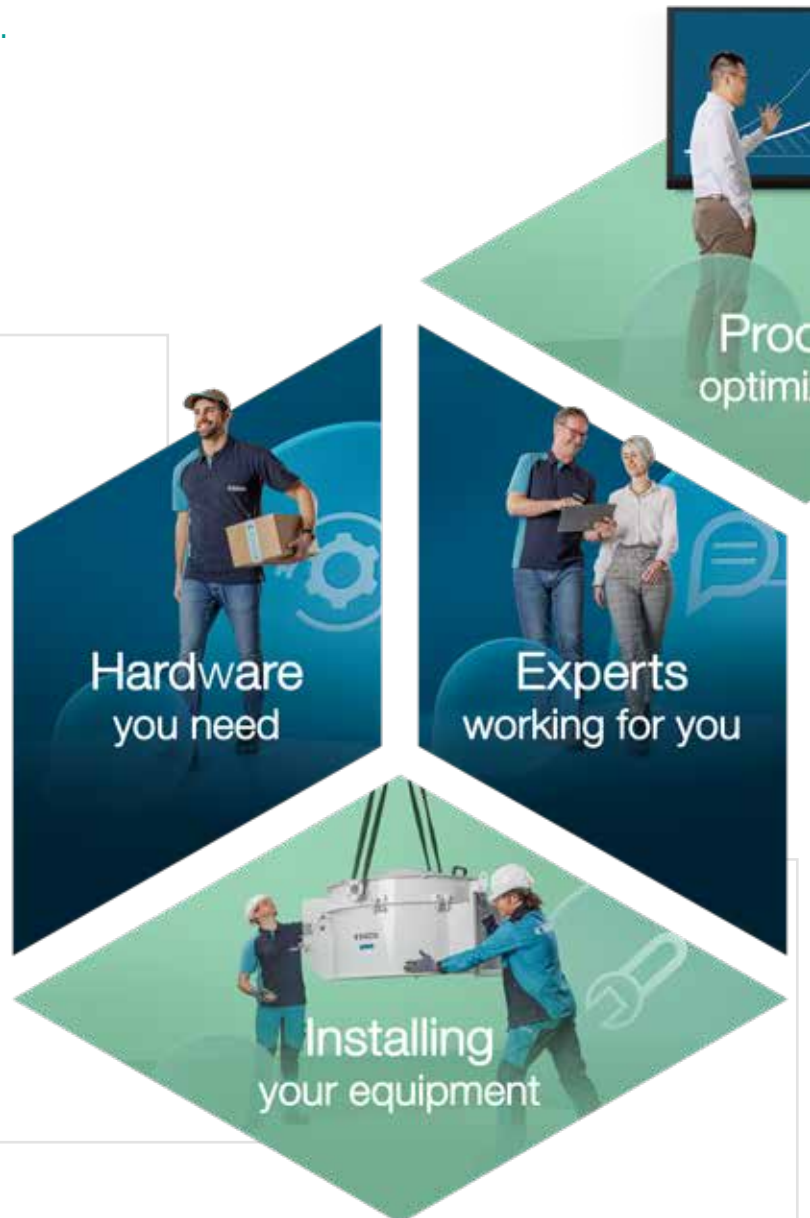

We own over 160 years of industry and process expertise, with valuable insights on both the technical knowledge as well as the latest market know-how: Whether you are struggling to choose the right direction or finding new opportunities – we are here to guide you directly one on one or via our Remote Support.

Get proactive and holistic views on operations, condition and performance of your assets. Our goal is to improve your productivity by looking at your entire process, analyzing it and implementing sustainable solutions that increase consistency.

At Bühler, we differentiate between three basic types of maintenance approaches: Reactive, preventive and predictive maintenance. To find the best service solutions for you installed assets, we will jointly develop the concept to address your challenges and targets.

Give your plant a second lease of life with a retrofit service or extend the lifetime of your machine with a factory revision. We offer several upgrade kits for complete overhauls of your equipment, adding up to 10 years to your machine's lifetime.

Your people play a key role in the performance and quality of your production. Our experts help develop their competencies and boost your business. We share our deep knowledge in various classroom and on-site trainings for your people to better understand the plants and processes for your best outcome maintaining your efficiency and safety. Learn from our research and analysis solutions to keep up in a competitive market.

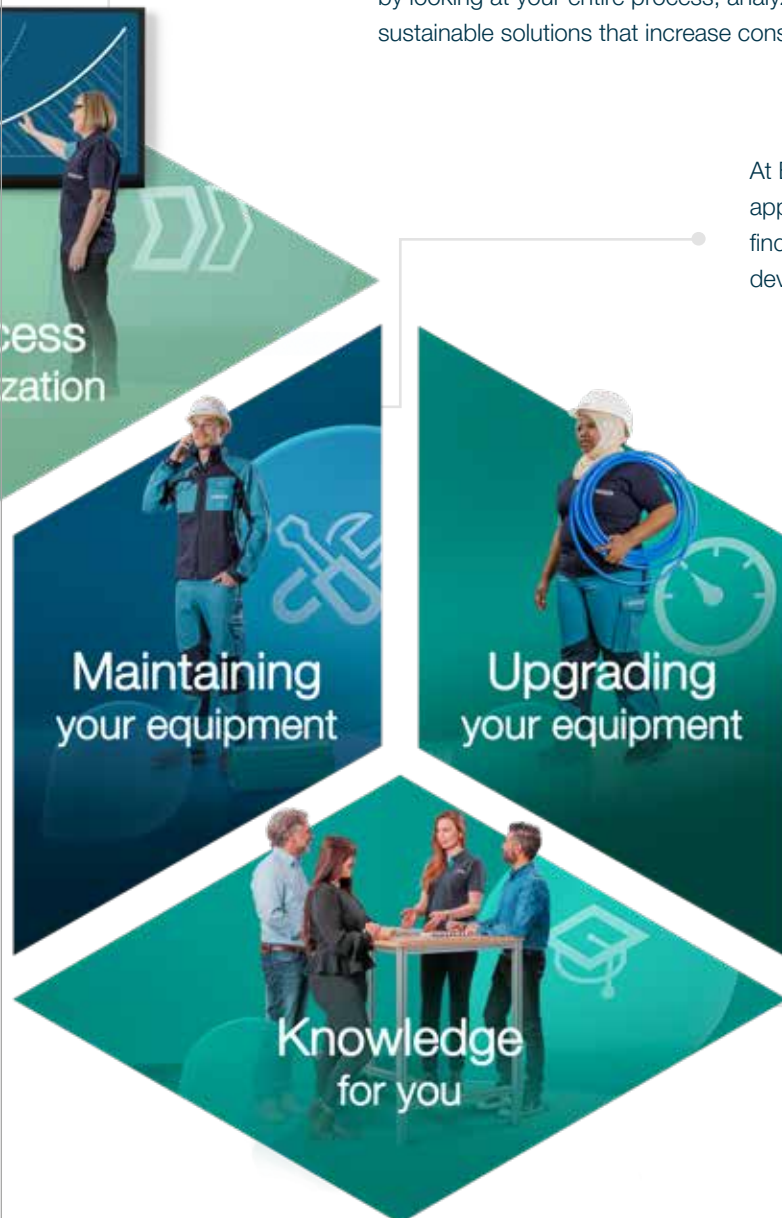

## **Bühler AG**

CH-9240 Uzwil  
Switzerland

T +41 71 955 11 11  
F +41 71 955 66 11

[www.buhlergroup.com/aquafeed](http://www.buhlergroup.com/aquafeed)  
[extrusion@buhlergroup.com](mailto:extrusion@buhlergroup.com)

Aqua feed brochure 243201 en 10/24 Z&B